

**Fig 288D**



# TOYO VALVES

StandardsMark: AS1628

Licence No. 1051

Manufactured by the TOYO Valve Co.

## Copper Alloy Gate Valve to AS 1628

### Nomenclature & Materials

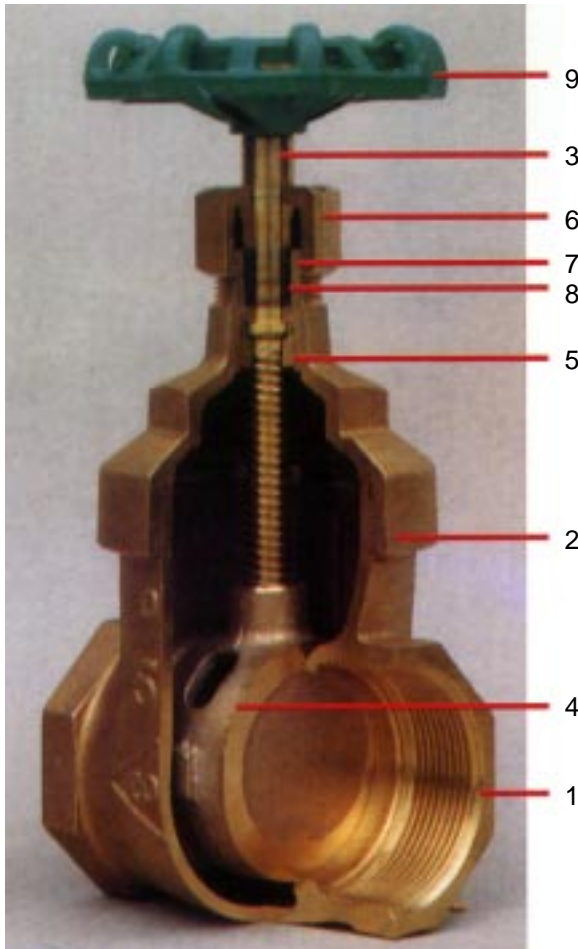

| Item No. | Part Name     | Material                            | Specification |
|----------|---------------|-------------------------------------|---------------|
| 1        | Body          | Cast Bronze                         | AS1565-C83600 |
| 2        | Bonnet        | Cast Bronze                         | AS1565-C83600 |
| 3        | Stem          | Copper Alloy Rod* TCA721S           | B21-C47940    |
| 4        | Disc          | Cast Bronze                         | AS1565-C83600 |
| 5        | Lock Nut      | Copper Alloy Rod* TCA721S           | B21-C47940    |
| 6        | Packing Nut   | Forged Brass                        | AS1567 380    |
| 7        | Gland         | Copper Alloy Rod* TCA721S           | B21-C47940    |
| 8        | Gland Packing | Non Asbestos Graphite               | #2996.NA      |
| 9        | Handwheel     | Ductile Iron or Die Cast Zinc Alloy | B86-Z33520    |
| 10       | Wheel Nut     | Forged Brass                        | AS1567-380    |
| 11       | Name Plate    | Aluminium Plate                     | B209-1100     |

\* Dezincification resist material (Toyo copper alloy Pat. No. 1389661)

**Note 1:** Toyo TCA 721S Copper Alloy has been registered as US. Alloy No. ASTM B21-C47940.

**Note 2:** Dezincification tests to AS2345. Tested by Arndel Limited, as registered member if N.A.T.A.

**Note 3:** End connections, screwed female pipe threads to AS1722 Part 2-1975 Series 'G'. (B.S.P. Parallel).

### Working Pressure

| Working Pressure     | Non-Shock (kPa) | Hydrostatic Test Pressure (kPa) |
|----------------------|-----------------|---------------------------------|
| Cold water, oil, gas | Shell (water)   | Seal (water)                    |
| 2100                 | 2500            | 2500                            |

### Dimensions

| Size | 15   | 20   | 25   | 32   | 40   | 50   |
|------|------|------|------|------|------|------|
| L    | 52   | 56   | 66   | 73   | 76   | 90   |
| H    | 89   | 100  | 122  | 135  | 149  | 183  |
| D    | 48   | 57   | 63   | 70   | 80   | 90   |
| Kg   | 0.37 | 0.50 | 0.85 | 1.10 | 1.20 | 2.10 |

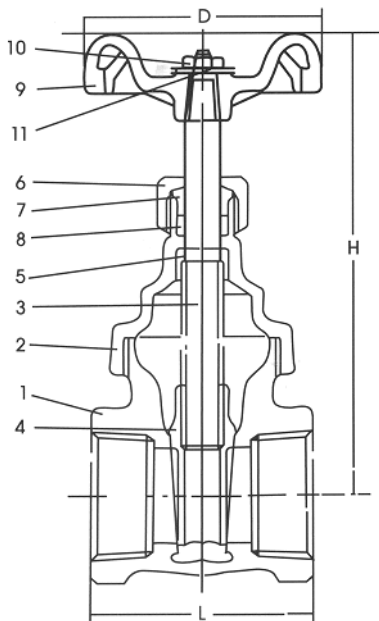

**SYDNEY**

Tel: (02) 9877 8101

Fax: (02) 9804 6282

aps.syd@powerflo.com.au

**BRISBANE**

Tel: (07) 3897 8100

Fax: (07) 3293 4261

aps.qld@powerflo.com.au

**PERTH**

Tel: (08) 9456 9600

Fax: (08) 9350 6644

aps.wa@powerflo.com.au

**MELBOURNE**

Clayton VIC 3168

Tel: (03) 8541 7888

Fax: (03) 8541 7899

aps.vic@powerflo.com.au

**NEW ZEALAND**

Tel: (64 9) 525 5454

Fax: (64 9) 579 3106

Mob: (64 2) 176 4053

salesnz@powerflo.co.nz



**AUSTRAL - POWERFLO SOLUTIONS**

Website: [www.austral-powerflo.com.au](http://www.austral-powerflo.com.au)

Toll Free: 1300 658 701