

**Gate, Globe & Check valves
Forged Steel
Socket weld end
Class 800, 1500, 2500
Size 1/2" - 2"**



Type GTF



Type GLF



Type PCF

Applications

- General Industry, power stations, process engineering
- For water, steam, gas, oil and other non-aggressive media
- Further applications on request

Operating data

- Pressure range upto 439 Bar/6250 PSI
- Temperature range up to +593°C/1100°F

Materials

- # A105 from 0° C to 425° C
- # A182 F22 from 0° C to 593° C

Design

- As per API 602 Gate Valve
- As per BS 5352 Globe Valve
- As per BS 5352 Check Valve
- As per ASME B 16.34 'Y' Globe Valve
- As per ASME B 16.34 'Y' Check Valve
- Welded Bonnet Design for # 1500 & # 2500
- Stellite hard-faced Seats
- Encapsulated gaskets for # 800 Valves

Variants on request

- 13% Cr Seats for # 800 Gate Valves
- Locking device
- Alternate packing / Gaskets
- Flanged Ends to # 150/300/600
- BW execution
- ST6 (HF) Wedge / Disc for High Temperatures beyond 350°C / 660°F
- Screwed Ends to NPT / BSP (Female) # 800
- Position indicator
- Other materials
- Other executions

On all enquiries / orders please specify

- | | |
|--------------------------|---|
| 1. Type | 8. Material of construction |
| 2. ANSI pressure class | 9. Flow medium |
| 3. Size | 10. Flow rate Min. / Max. |
| 4. Design pressure | 11. Type of end connection |
| 5. Operating pressure | 12. Variants |
| 6. Operating temperature | 13. Leaflet number |
| 7. Differential pressure | 14. Valve data sheet
(if applicable) |

Operating instructions no. : 0500.80/03 - 18 G3

When ordering spares indicate valve serial number.



Pressure Temperature Chart

MATERIAL : A 105 Standard Class

NOTE : Permissible, but not recommended for prolonged usage above about 800°F

Temperature		Pressure class											
		# 150		# 300		# 600		# 800*		# 1500		# 2500	
		°F	°C	PSI	kg/cm ²	PSI	kg/cm ²	PSI	kg/cm ²	PSI	kg/cm ²	PSI	kg/cm ²
-20 to 100	-17 to 38	285	20.0	740	52.0	1480	104.1	1975	138.8	3705	260.5	6170	433.8
200	93.3	260	18.3	675	47.5	1350	94.9	1800	126.5	3375	237.3	5625	395.5
300	148.9	230	16.2	655	46.1	1315	92.5	1750	123	3280	230.6	5470	384.6
400	204.4	200	14.1	635	44.6	1270	89.3	1690	118.8	3170	222.9	5280	371.2
500	260	170	12.0	600	42.2	1200	84.4	1595	112	2995	210.6	4990	350.8
600	315.6	140	9.8	550	38.7	1095	77	1460	102.6	2735	192.3	4560	320.6
650	343.3	125	8.8	535	37.6	1075	75.6	1430	100.5	2685	188.8	4475	314.6
700	371.1	110	7.7	535	37.6	1065	74.9	1420	99.8	2665	187.4	4440	312.2
750	398.9	95	6.7	505	35.5	1010	71	1345	94.6	2520	177.2	4200	295.3
800	426.7	80	5.6	410	28.8	825	58	1100	77.3	2060	144.8	3430	241.2
850	454.4	65	4.6	270	19.0	535	37.6	715	50.3	1340	94.2	2230	156.8
900	482.2	50	3.5	170	12.0	345	24.3	460	32.3	860	60.5	1430	100.5
950	510	35	2.5	105	7.4	205	14.4	275	19.3	515	36.2	860	60.5
1000	537.8	20	1.4	50	3.5	105	7.4	140	9.9	260	18.3	430	30.2

MATERIAL : A 182 F22 Standard Class

NOTE : Use normalised and tempered material only

Temperature		Pressure class											
		# 150		# 300		# 600		# 800*		# 1500		# 2500	
		°F	°C	PSI	kg/cm ²	PSI	kg/cm ²	PSI	kg/cm ²	PSI	kg/cm ²	PSI	kg/cm ²
-20 to 100	-17 to 38	290	20.4	750	52.7	1500	105.5	2000	140.5	3750	263.7	6250	439.4
200	93.3	260	18.3	715	52.7	1500	105.5	1910	134.2	3750	263.7	6250	439.4
300	148.9	230	16.2	730	51.3	1455	102.3	1805	126.8	3640	255.9	6070	426.8
400	204.4	200	14.1	705	49.6	1410	99.1	1730	121.6	3530	248.2	5880	413.4
500	260	170	12	665	46.8	1330	93.5	1705	119.8	3325	233.8	5540	389.5
600	315.6	140	9.8	605	42.5	1210	85.1	1615	113.5	3025	212.7	5040	354.4
650	343.3	125	8.8	590	41.5	1175	82.6	1570	110.3	2940	206.7	4905	344.9
700	371.1	110	7.7	570	40.1	1135	79.8	1515	106.5	2840	199.7	4730	332.6
750	398.9	95	6.7	530	37.3	1065	74.9	1420	99.8	2660	187.0	4430	311.5
800	426.7	80	5.6	510	35.9	1015	71.4	1355	95.2	2540	178.6	4230	297.4
850	454.4	65	4.6	485	34.1	975	68.6	1300	91.4	2435	171.2	4060	285.5
900	482.2	50	3.5	450	31.6	900	63.3	1200	84.3	2245	157.8	3745	263.3
950	510	35	2.5	375	26.4	755	53.1	1005	70.6	1885	132.5	3145	221.1
1000	537.8	20	1.4	260	18.3	520	36.6	715	50.2	1305	91.8	2170	152.6
1050	565.6	20	1.4	175	12.3	350	24.6	530	37.2	875	61.5	1455	102.3
1100	593.3	20	1.4	110	7.7	220	15.5	300	21.1	550	38.7	915	64.3
1150	621.1	20	1.4	70	4.9	135	9.5	275	19.3	345	24.3	570	40.1
1200	648.9	20	1.4	40	2.8	80	5.6	145	10.2	205	14.4	345	24.3

* Pressure/Temperature Class Values as per API 602

800 GLOBE VALVE
A. DESIGN / TEST SPECIFICATIONS

TEST (API 598)	(kg/cm ²)	(PSI)	TESTING MEDIUM
SHELL	210	2963	WATER
BACK SEAT	153	2173	
SEAT LEAK	153	2173	
DESIGN SPECIFICATIONS			
GENERAL VALVE DESIGN			BS 5352 / ISO 15761
PRESSURE TEMPERATURE RATINGS			ASME B16.34
SOCKET WELD END DIMENSIONS			ASME B16.11
END TO END AS PER MANUFACTURER'S STANDARD			

B. MATERIAL

PART NO.	PART NAME	MATERIALS AS PER ASTM	
100	BODY	A 105	A 182-F316L
166	BONNET	A 105	A 182-F316L
200	STEM	A 479-410-2	A 276-316L
360	DISC	A 276-410 (H)	A 351-CF3M
411	GASKET	SS + GRPH	SS+GRPH
452	GLAND FLANGE	A 105	A 182-F316L
456	GLAND BUSH	A 276-410	A 276-316L
461	GLAND PACKING	GRAPHITE	GRAPHITE
515	SEAT	ST6 (INTEGRAL)	A 276-316L
544	STEM NUT	A 582-416	A 582-416
901	HEX BOLT	A 193-B7	A 193-B8M
902	STUD	A 193-B6	A 193-B8M
920	HEX NUT	A 194-2H	A 194-B8
961	HAND WHEEL	A 216 WCB	

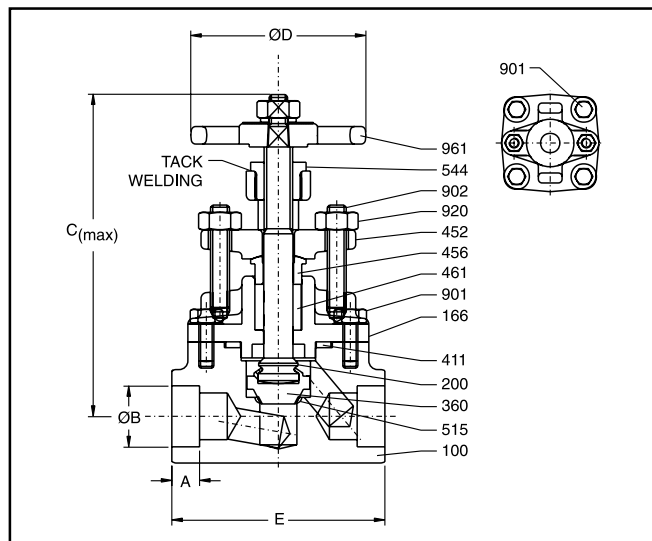
C. DIMENSIONS

SIZE		E		ØB		C(max)		ØD		A	
INCH	MM	INCH	MM	INCH	MM	INCH	MM	INCH	MM	INCH	MM
1/2	15	2.9	73	0.9	21.8	4.7	118	3.0	75	0.4	9.5
3/4	20	3.2	82	1.1	27.2	5.2	133	3.0	75	0.5	12.7
1	25	4.3	108	1.3	33.9	5.8	148	4.7	120	0.5	12.7
1½	40	6.0	152	1.9	48.8	8.0	202	5.7	144	0.5	12.7
2	50	5.8	148	2.4	61.2	10.4	265	5.7	144	0.6	16.0

1500 GLOBE VALVE
A. DESIGN / TEST SPECIFICATIONS

TEST (API 598)	(kg/cm ²)	(PSI)	TESTING MEDIUM
SHELL	396	5625	WATER
BACK SEAT	291	4125	
SEAT LEAK	291	4125	
DESIGN SPECIFICATIONS			
GENERAL VALVE DESIGN			BS 5352 / ISO 15761
PPRESSURE TEMPERATURE RATINGS			ASME B16.34
SOCKET WELD END DIMENSIONS			ASME B16.11
END TO END AS PER MANUFACTURER'S STANDARD			

B. MATERIAL

PART NO.	PART NAME	MATERIALS AS PER ASTM	
100	BODY	A 105	A 182 F22
166	BONNET	A 105	A 182 F22
200	STEM	A 479-410-2	A 479-410-2
350	DISC	A 276-410 (H)	SS 304+ST6
452	GLAND FLANGE	A 105	A 105
456	GLAND BUSH	A 276-410	A 276-410
461	GLAND PACKING	GRAPHITE	GRAPHITE
515	SEAT	ST6 (INTEGRAL)	ST6 (INTEGRAL)
544	STEM NUT	A 582-416	A 582-416
902	STUD	A 193-B8M Cl.2	A 193-B8M Cl.2
920	HEX NUT	A 194-2H	A 194-2H
961	HAND WHEEL	IS 2108-BM 340 / SG IRON	

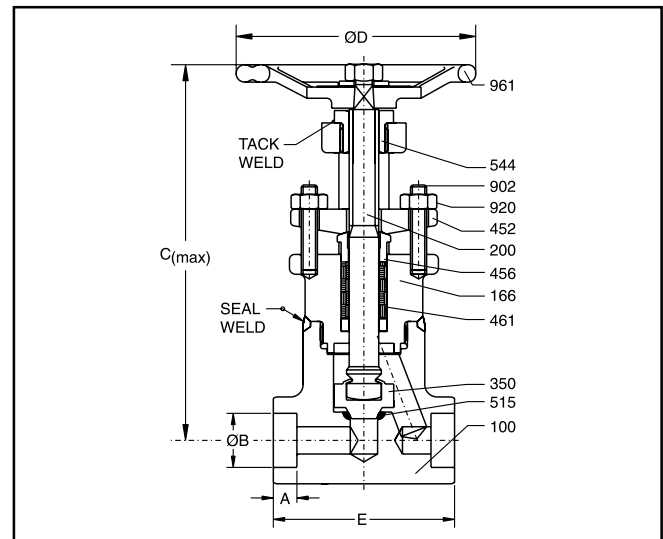
C. DIMENSIONS

SIZE		E		ØB		C(max)		ØD		A	
INCH	MM	INCH	MM	INCH	MM	INCH	MM	INCH	MM	INCH	MM
1/2	15	2.9	73	0.9	21.8	6.7	171	5.0	127	0.4	9.5
3/4	20	3.7	94	1.1	27.2	8.7	220	7.3	185	0.5	12.5
1	25	4.8	122	1.3	33.9	9.3	236	7.3	185	0.5	12.5
1½	40	6.3	160	1.9	48.8	11.6	295	8.0	203	0.5	12.5
2	50	7.0	178	2.4	61.2	12.2	310	8.0	203	0.6	16.0

800 CHECK VALVE

A. DESIGN / TEST SPECIFICATIONS

TEST (API 598)	(kg/cm ²)	(PSI)	TESTING MEDIUM
SHELL	210	2963	WATER
SEAT LEAK	153	2173	
DESIGN SPECIFICATIONS			
GENERAL VALVE DESIGN			BS 5352 / ISO 15761
PRESSURE TEMPERATURE RATINGS			ASME B16.34
SOCKET WELD END DIMENSIONS			ASME B16.11
END TO END AS PER MANUFACTURER'S STANDARD			

B. MATERIAL

PART NO.	PART NAME	MATERIALS AS PER ASTM	
100	BODY	A 105	A 182-316L
160	COVER	A 105	A 182-316L
351	DISC	A 276-410 (H)	A 276-316L
411	GASKET	SS + GRPH	SS + GRPH
515	SEAT	ST6 (INTEGRAL)	INTEGRAL
901	HEXBOLT	A 193-B7	A 193 - B8M Cl. 2
950	SPRING	A 313-SS 302	SS 304

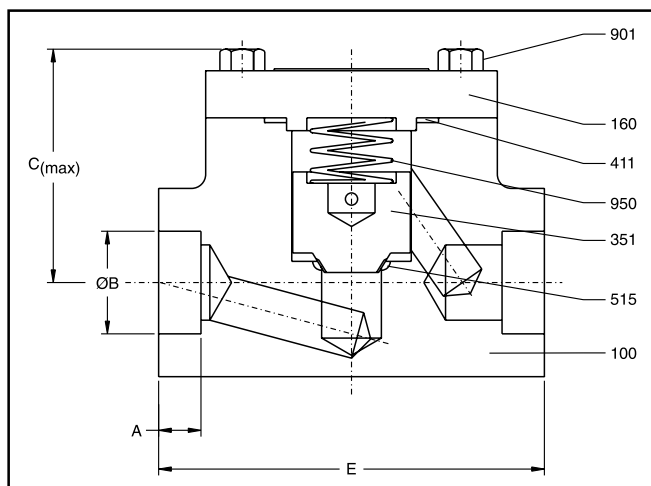

C. DIMENSIONS

SIZE		E		ØB		C(max)		A	
INCH	MM	INCH	MM	INCH	MM	INCH	MM	INCH	MM
1/2	15	2.9	73	0.9	21.8	2.0	50	0.4	9.5
3/4	20	3.2	82	1.1	27.2	2.4	60	0.5	12.5
1	25	4.3	108	1.3	33.9	2.6	65	0.5	12.5
1½	40	6.0	152	1.9	48.8	3.5	90	0.5	12.5
2	50	5.8	148	2.4	61.2	4.9	125	0.6	16.0

1500 CHECK VALVE

A. DESIGN / TEST SPECIFICATIONS

TEST (API 598)	(kg/cm ²)	(PSI)	TESTING MEDIUM
SHELL	396	5625	WATER
SEAT LEAK	291	4125	
DESIGN SPECIFICATIONS			
GENERAL VALVE DESIGN			BS 5352 / ISO 15761
PRESSURE TEMPERATURE RATINGS			ASME B16.34
SOCKET WELD END DIMENSIONS			ASME B16.11
END TO END AS PER MANUFACTURER'S STANDARD			

B. MATERIAL

PART NO.	PART NAME	MATERIALS AS PER ASTM	
100	BODY	A 105	A 182 - F22
160	COVER	A 105	A 182 - F22
351	DISC	A 276-410 (H)	SS 304 + ST6
515	SEAT	ST6 (INTEGRAL)	ST6 (INTEGRAL)
950	SPRING	A 313 - SS 302	A 313 - SS 302

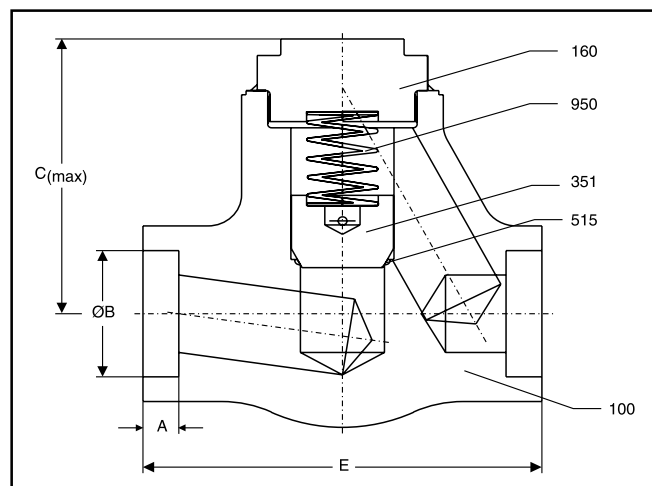

C. DIMENSIONS

SIZE		E		ØB		C		A	
INCH	MM	INCH	MM	INCH	MM	INCH	MM	INCH	MM
1/2	15	2.9	73	0.9	21.8	2.6	65	0.4	9.5
3/4	20	3.7	94	1.1	27.2	3.1	80	0.5	12.5
1	25	4.8	122	1.3	33.9	3.7	95	0.5	12.5
1½	40	6.3	160	1.9	48.8	4.7	120	0.5	12.5
2	50	7.0	178	2.4	61.2	5.5	140	0.6	16.0

2500 Y - GLOBE
A. DESIGN / TEST SPECIFICATIONS

TEST (API 598)	(kg/cm ²)	(PSI)	TESTING MEDIUM
SHELL	660	9375	WATER
BACK SEAT	484	6875	
SEAT LEAK	484	6875	
DESIGN SPECIFICATIONS			
GENERAL VALVE DESIGN & PR. TEMP. RATING			ASME B16.34
SOCKET WELD END DIMENSIONS			ASME B16.11
END TO END AS PER MANUFACTURER'S STANDARD			

B. MATERIAL

PART NO.	PART NAME	MATERIALS AS PER ASTM	
100	BODY	A 105	A 182-F22
166	BONNET	A 105	A 182-F22
200	STEM	A 479-410-2	A 479-410-2
350	DISC	SS 304 + ST6	SS 304 + ST6
452	GLAND FLANGE	A 105	A 105
456	GLAND BUSH	A 276-410	A 276-410
461	GLAND PACKING	GRAPHITE	GRAPHITE
515	SEAT	ST6 (INTEGRAL)	ST6 (INTEGRAL)
544	STEM NUT	A 582-416	A 582-416
902	STUD	A 193-B8M Cl.2	A 193-B8M Cl.2
920	HEX NUT	A 194-2H	A 194-2H
961	HAND WHEEL	IS 2108-BM 340 / SG IRON	

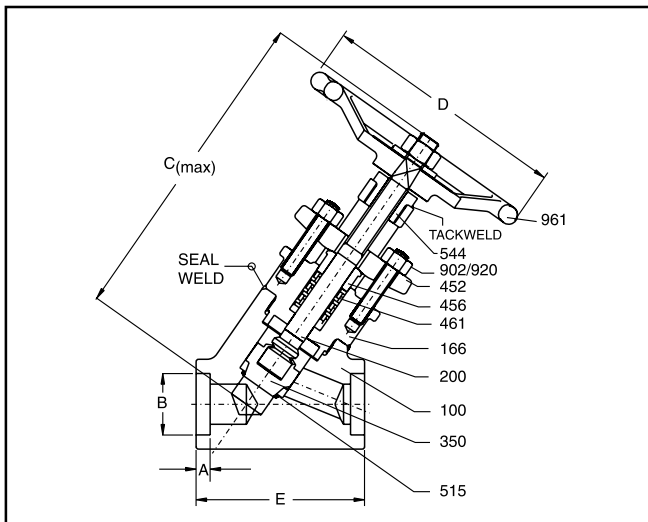
C. DIMENSIONS

SIZE		E		ØB		C(max)		ØD		A	
INCH	MM	INCH	MM	INCH	MM	INCH	MM	INCH	MM	INCH	MM
1/2	15	3.3	85	0.9	21.8	7.3	186	5.0	127	0.4	9.5
3/4	20	3.9	98	1.1	27.2	8.7	220	7.3	185	0.5	12.5
1	25	4.1	104	1.3	33.9	9.5	240	7.3	185	0.5	12.5
1½	40	5.7	144	1.9	48.8	11.8	300	8.0	203	0.5	12.5
2	50	5.7	144	2.4	61.2	15.0	380	10.0	255	0.6	16.0

2500 Y - CHECK
A. DESIGN / TEST SPECIFICATIONS

TEST (API 598)	(Kg/cm ²)	(PSI)	TESTING MEDIUM
SHELL	660	9375	WATER
SEAT LEAK	484	6875	
DESIGN SPECIFICATIONS			
GENERAL VALVE DESIGN & PR. TEMP. RATING			ASME B16.34
SOCKET WELD END DIMENSIONS			ASME B16.11
END TO END AS PER MANUFACTURER'S STANDARD			

B. MATERIAL

PART NO.	PART NAME	MATERIALS AS PER ASTM	
100	BODY	A105	A182 - F22
160	COVER	A105	A182 - F22
351	DISC	SS 304 + ST6	SS 304 + ST6
515	SEAT	ST6 (INTEGRAL)	ST6 (INTEGRAL)
950	SPRING	A 313-SS 302	A 313-SS 302

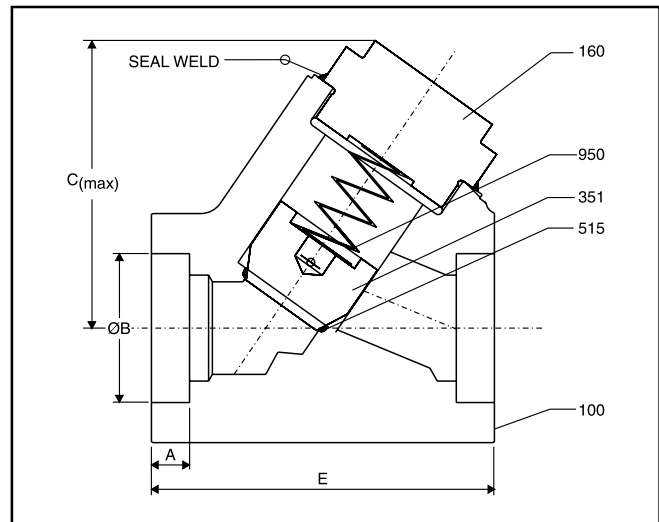

C. DIMENSIONS

SIZE		E		ØB		C(max)		A	
INCH	MM	INCH	MM	INCH	MM	INCH	MM	INCH	MM
1/2	15	3.4	85	0.9	21.8	3.0	76	0.4	9.5
3/4	20	3.9	98	1.1	27.2	3.0	76	0.5	12.5
1	25	4.1	104	1.3	33.9	3.5	90	0.5	12.5
1½	40	5.7	144	1.9	48.8	4.7	120	0.5	12.5
2	50	5.7	144	2.4	61.2	5.0	127	0.6	16.0

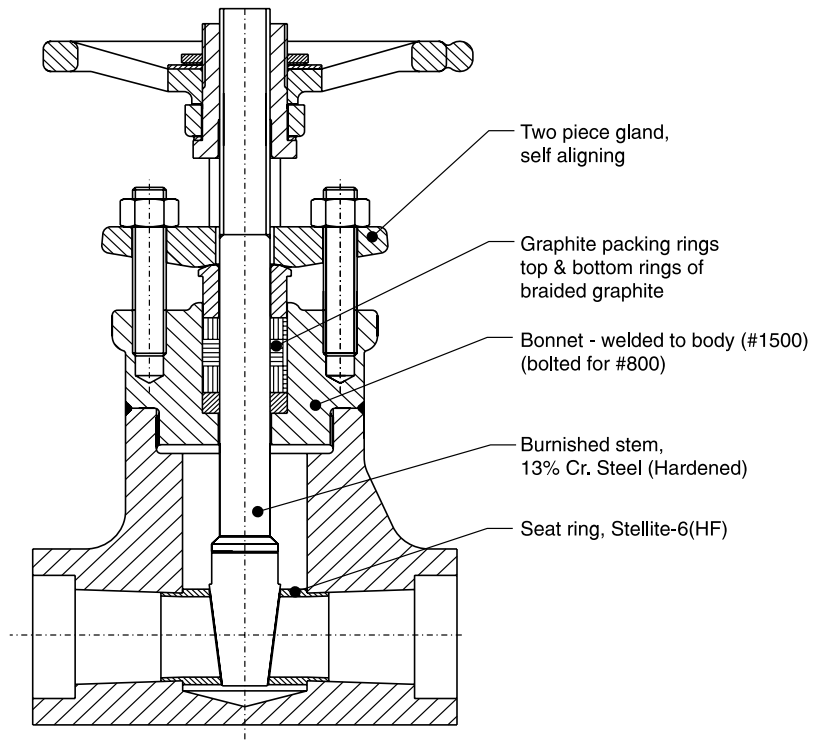
Product features to our Customer's benefit

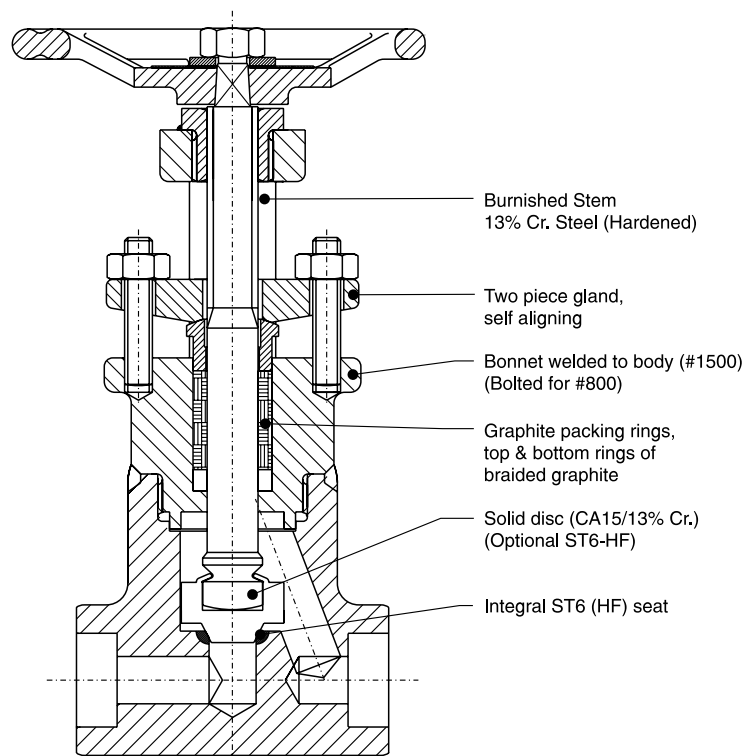

Gate Valve



Globe Valve

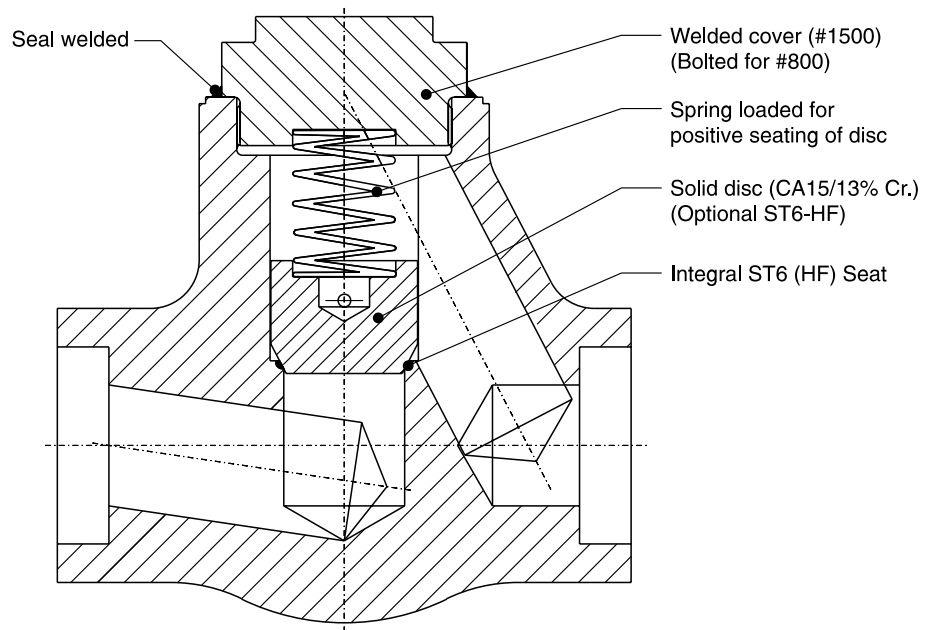

Check Valve

Technical matter. Subject to change without notice.



KSB PUMPS LTD.

151, NSN Palayam Post, Mettupalayam Road, Coimbatore 641 031.

Tel. : +91 422 2468222 Fax : +91 422 2468232 e-mail : cbgvalves@ksb.co.in www.ksbindia.co.in